

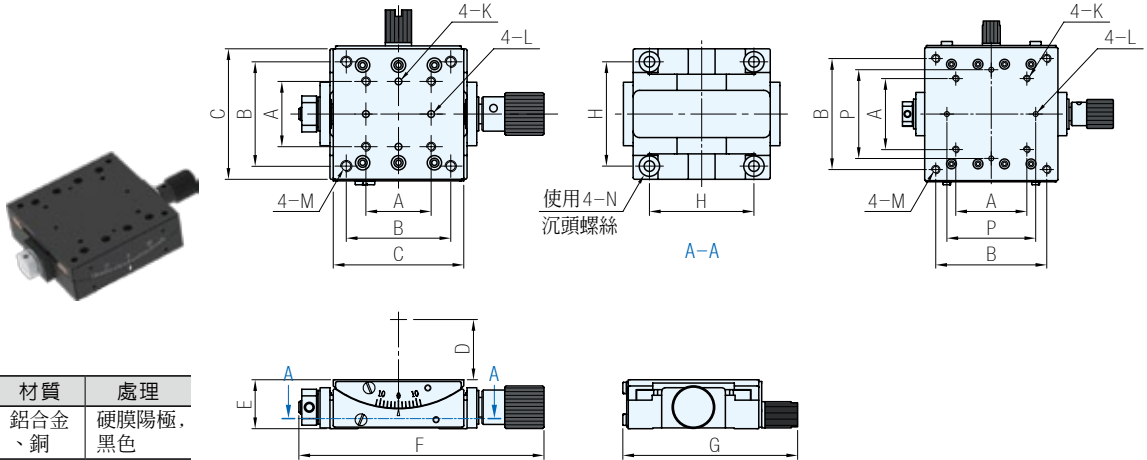

檯面40、50

檯面60



材質	處理
鋁合金、銅	硬膜陽極、黑色

品號	檯面	行程角度	旋轉中心高度	最小刻度量	每圈移動量	水平載重 kg	垂直載重 kg	本體重量 kg
AFM-0010	40	±10°	25	1°	≒0.85°	5	3	0.09
AFM-0011		±15°	40		≒0.54°			
AFM-0012		±10°	60		≒0.39°			
AFM-0013	50	±10°	50		≒0.47°	6	4	0.16
AFM-0014		±10°	68		≒0.36°			
AFM-0015		±8°	86		≒0.29°			
AFM-0016	60	±20°	35		≒0.54°	7	5	0.23
AFM-0017		±15°	60		≒0.39°			
AFM-0018		±12°	80		≒0.31°			

品號	檯面 C	A	B	D	E	F	G	H	K	L	M	N 內六角螺絲	P	
AFM-0010	40	20	32	25	15	(75.2)	(53.7)	32	M2×0.4P×3.0深	φ2H7×2深	M3×0.5P×3.0深	M3	-	
AFM-0011				40	20				M2×0.4P×5.0深		M3×0.5P×3.5深			
AFM-0012				60	20				M2×0.4P×5.0深		M3×0.5P×3.5深			
AFM-0013	50	30	40	50	18	(85.0)	(63.6)	40	M3×0.5P×2.5深	φ2H7×2深	M3×0.5P×2.5深	M3	-	
AFM-0014				68					18		M3×0.5P×2.5深			M3×0.5P×2.5深
AFM-0015				86					18		M3×0.5P×2.5深			M3×0.5P×2.5深
AFM-0016	60	32	50	35	25	(95.0)	(73.6)	50	M3×0.5P×4.5深	φ2H7×2深	M4×0.7P×4.5深	M4	40	
AFM-0017				60	20				M3×0.5P×4.5深		M4×0.7P×4.5深			
AFM-0018				80	20				M3×0.5P×3.0深		M4×0.7P×3.0深			

Sp. 特長

- 應用於影像量測系統、半導體設備、定位控制系統、組裝點膠、檢測設備

訂貨： 交期： 天

AFM-0010

Te. 技術資料

- αβ雙軸堆疊品號搭配：
- 正確搭配才能使旋轉中心高度一致

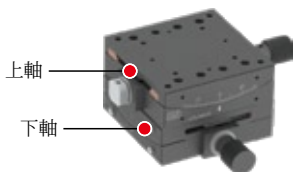

檯面	40		50		60	
上軸	AFM-0010	AFM-0011	AFM-0013	AFM-0014	AFM-0016	AFM-0017
下軸	AFM-0011	AFM-0012	AFM-0014	AFM-0015	AFM-0017	AFM-0018